

LITHIUM ION PHOSPHATE BATTERY

ELBT LiFePO4 series batteries offer BMS controlled safety, long life,fast-charging performance(Optional Bluetooth function,which can real-time Bluetooth Access to battery SOC,Voltage, Current, Temperature status). The BMS embeds smart balancing algorithms that control all cell voltages in the battery, making sure they are constantly at the same voltage level, optimizing battery capacity.



ELECTRICAL SPECIFICATION	
Nominal Voltage	25.6V
Nominal Capacity	100AH
Stored Energy	2560Wh
Resistance	50 mΩ
Self Discharge Rate	<3% per Month
Maximum Continous Charge Current	50A
Maximum Continous Discharge Current	100A
Charge Cut-off Voltage	31.2 V
Discharge Cut-off Voltage	20V
Cycle life(25°C)	>4000 times@80%DOD

MECHANICAL SPECIFICATIONS	
Dimensions (mm)	L520×W268×H228
Weight	24kg
Terminal Type	M8
Case Material	ABS
Enclosure protection	IP64
Enclosure Protection	Enclosure Protection

TEMPERATURE SPECIFICATIONS	
Discharge Temperature	0 to 55 °C
Charge Temperature	-10 to 55 °C
Storage Temperature	-20 to 60 °C
Enclosure Protection	Enclosure Protection

OTHERS SPECIFICATIONS	
Short Circuit Protection	Automatically recover after removal of short
Life Expectancy (years)	10 years at one cycle per day



INTELLIGENT BMS FUNCTION

- Overcharge detection function
- Over discharge detection function
- Over current detection function
- Short detection function
- Temperature detection function
- Balance function

BLUETOOTH® ENABLED

Monitor the State of Charge (SoC), State of Health (SoH), current, capacity, temperature, number of cycles, and voltage levels of the battery and individual cells from APP.



BATTERY FEATURES

- Super safe lithium iron phosphate (LiFePO4) chemistry reducing the risk of explosion or combustion due to high impact, over-charging or short circuit situation.
- Bluetooth® communication capability for battery status through ELB APP.
- Battery Management System (BMS) controls the parameters of the battery to provide optimum safety by protecting against over-charging and over-discharging.
- BMS enhanced design balances the battery cells, optimizing battery performance.
- Delivers twice the power of lead acid batteries, even at high discharge rates, while maintaining high energy capacity.
- Faster charging and lower self-discharge.
- Up to 10 times more cycles than lead acid batteries.
- Compact and only 40% of the weight of comparable lead acid batteries.

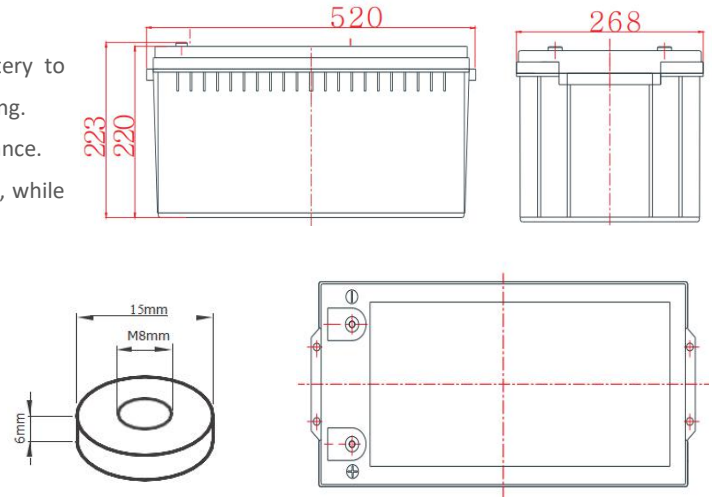

PERFORMANCE CHARACTERISTICS

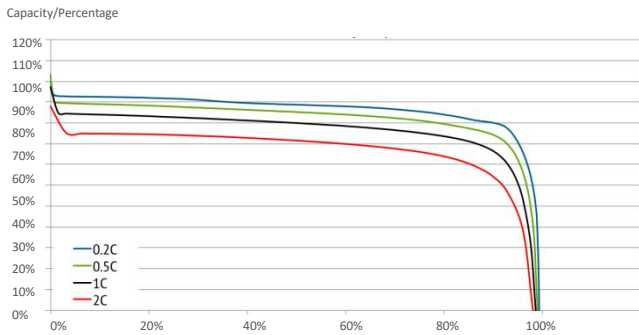

Discharge voltage Characteristic at different Rate@25°C

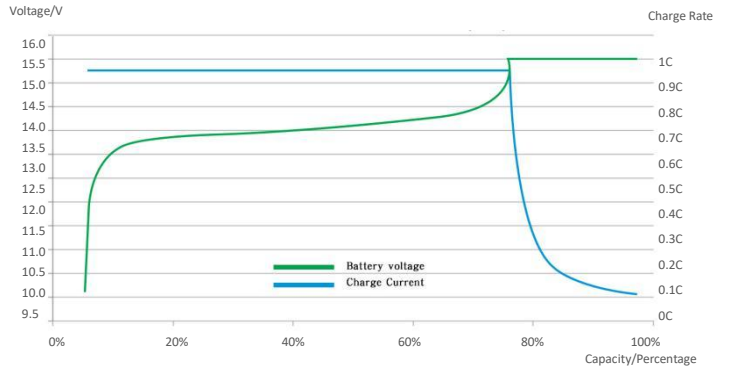

Charging characteristic (0.2C @ 25°C)

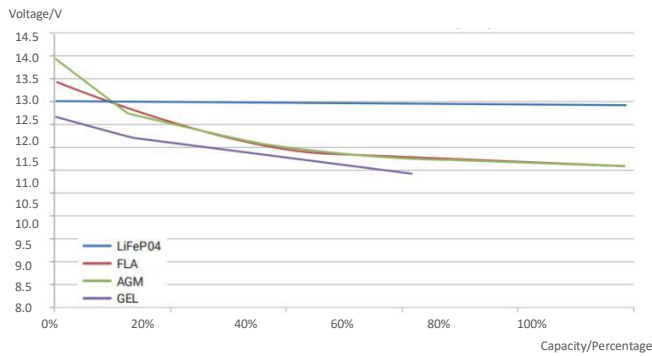

Capacity of LiFePO4 vs. Lead acid@Different current of discharge

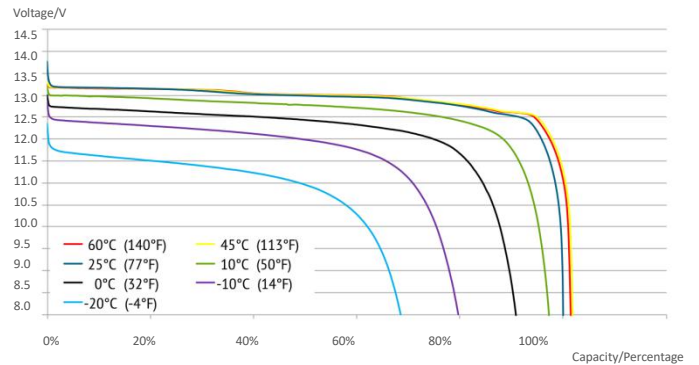

Discharge voltage Characteristic at different Temperature

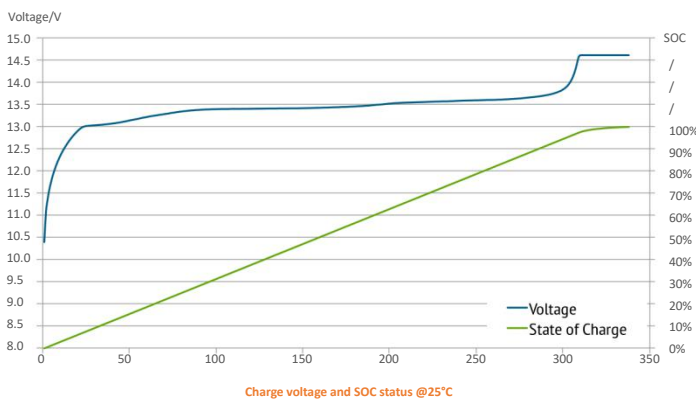

Charge voltage and SOC status @25°C

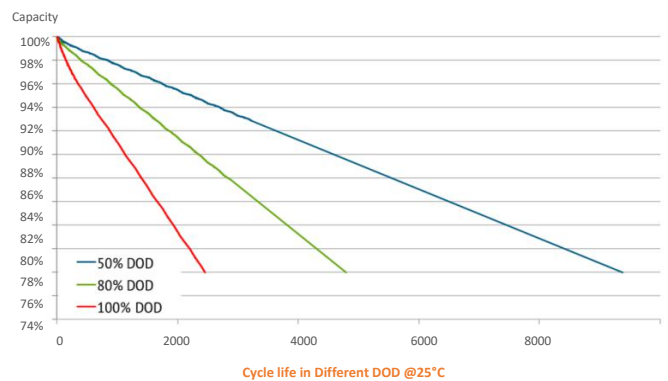

Cycle life in Different DOD @25°C

STANDARD CHARGE AND DISCHARGE

Standard Charge

- Charge at 0.2C constant current until the battery reaches 14.6V. The battery then charges at constant voltage of 14.6V while tapering the charge current. Charging will end when the current has tapered to 0.05C. The battery should be charged between 0°C and 45°C, then rest for 30 minutes before discharging. Do not exceed the max charging current, voltage, or temperature limits as specified in this document. Do not reverse-polarity charge the battery.

Standard Discharge

- Battery should be discharged at a constant current of 0.2C to 10.0V at $20 \pm 5^\circ\text{C}$, then rest for 30 minutes before charging.

Storage

- The batteries should be stored open circuit, and protected against the possibility of a short between the terminals. The battery should be charged once every 6 months if not in use to prevent over-discharging. They batteries should be stored at room temperature, and charged to 30-50% SOC.

Warnings

- If the battery is over-charged and over-discharged too frequently, this will affect the long-term performance and capacity of the battery. If the battery is stored for too long, reduced capacity and performance can be expected. It is important to cycle the battery at least once every 6 months and stored at the appropriate SOC to prevent deterioration to the battery.

BATTERIES PARALLEL CONNECTION GUIDE



PARALLEL CONNECTION GUIDELINES

CAUTION:

- Severe damage to the battery, short circuiting and sparking will happen if the batteries are not connected correctly or properly maintained. We recommend assembly be completed by fully trained professionals only.
- Do not reverse connect the anode and cathode, as this will damage the batteries and/or any equipment connected.
- DO not connect the batteries in parallel AND series at the same time.

Before install

- Ensure wires can withstand twice the capacity rating of the battery. (Ex: ELBW100-LFP has a capacity of 100Ah, so the wire must be able to withstand 200A.)
- Charge all batteries with 14.6V per standard charge.
- Ensure all batteries have the same voltage level by fully charging each battery prior to connecting in parallel. (Voltage difference <0.2V)

Install

- Make sure the connections are tight and the connector is protected from corrosion, wear, and seismic situations. Connecting impedance <0.1m Ω
- DO NOT connect more than 4 batteries per circuit.

Maintenance

- Make sure capacity stays within 50-60% when storing the batteries. The temperature should be 0-35 °C, humidity 75-85% and fully charged every 3 months and discharged to 50-60% capacity.
- Once a year, the batteries should be removed from string and individually charged. The voltage difference upon reassembly should be no more than 0.2V.

BATTERIES SERIES CONNECTION GUIDE

General positive

General negative



SERIES CONNECTION GUIDELINES

CAUTION:

- Severe damage to the battery, short circuiting and sparking will happen if the batteries are not connected correctly or properly maintained. We recommend assembly be completed by fully trained professionals only.
- Do not reverse connect the anode and cathode, as this will damage the batteries and/or any equipment connected.
- DO NOT connect the batteries in parallel AND series at the same time.

Before install

- Ensure wires can withstand twice the capacity rating of the battery. (Ex: ELBW100-LFP has a capacity of 100Ah, so the wire must be able to withstand 200A.)
- Charge all single batteries with 14.6V per standard charge and series batteries at a voltage of 14.6 times the number of batteries in series.
- Ensure all batteries have the same voltage level by fully charging each battery prior to connecting in series. (Voltage difference <0.2V)

Install

- Make sure the connections are tight and the connector is protected from corrosion, wear, and seismic situations. Connecting impedance <0.1m Ω
- DO NOT connect more than 4 batteries per circuit for the ELBT Series line

Maintenance

- Make sure capacity stays within 50-60% when storing the batteries. The temperature should be 0-35 °C, humidity 75-85% and fully charged every 3 months and discharged to 50-60% capacity.
- Once a year, the batteries should be removed from string and individually charged. The voltage difference upon reassembly should be no more than 0.2V..

ELB

ELB ENERGY GROUP (SHENZHEN)LIMITED

Website: <https://www.ecolithiumbattery.com/>

Tel: (86)755-45963729

Mobile: +86 17746563763

Email: Info@ecolithiumbattery.com

Address: Lianhua industrial Zone, Huasheng Road, Dalang street, Longhua District, Shenzhen, China